

IES-3162GC



ORing WEB-site

Industrial 18-port managed Ethernet switch with 16x10/100Base-T(X) and 2xGigabit combo ports, SFP socket

Features

- World's fastest Redundant Ethernet Ring: O-Ring (recovery time < 10/30ms over 250 units of connection)
- O-Chain allow multiple redundant network rings
- Support standard IEC 62439-2 MRP^{NOTE} (Media Redundancy Protocol) function
- MSTP/RSTP/STP (IEEE 802.1s/w/D)
- Support Auto Negotiation Speed
- Support PTP Client (Precision Time Protocol) clock synchronization
- Support Modbus/TCP protocol
- IGMP v2/v3 (IGMP snooping for support) filtering multicast traffic
- Port Trunking for easy of bandwidth management
- Event notification through Syslog, Email, SNMP trap, and Relay Output
- RMON for traffic monitoring
- Support LLDP protocol
- Port lock to prevent access from unauthorized MAC address
- Windows utility (Open-Vision) support centralized management and configurable by Web-based, Telnet, Console (CLI)
- Support two Gigabit combo ports
- Rigid IP-30 housing design
- DIN-Rail and wall mounting enabled
- Multiple notification for warning of unexpected event
- Web-based, Telnet, Console (CLI), and Windows Utility (**Open-Vision**) configuration
- Support LLDP Protocol



*NOTE: This function is available by request only

Introduction

IES-3162GC is managed Redundant Ring Ethernet switch with 16x10/100Base-T(X) ports and 2xGigabit combo ports. With completely support of Ethernet Redundancy protocol, O-Ring (recovery time < 10/30ms over 250 units of connection), O-Chain, MRP^{NOTE} and MSTP/RSTP/STP (IEEE 802.1s/w/D) can protect your mission-critical applications from network interruptions or temporary malfunctions with its fast recovery technology. O-Chain is the revolutionary network redundancy technology that provides the add-on network redundancy topology for any backbone network, O-Chain allows multiple redundant network rings of different redundancy protocols to join and function together as a larger and more robust compound network topology. O-Chain providing ease-of-use while maximizing fault-recovery swiftness, flexibility, compatibility, and cost-effectiveness in one set of network redundancy topology. All function of IES-3162GC can be managed centralized and convenient by a powerful windows utility — Open-Vision. In addition, the wide operating temperature range from -40 to 75°C can satisfy most of operating environment. Therefore, the switch is one of the most reliable choice for highly-managed and Fiber Ethernet application.

- **O-Ring:** O-Ring is ORing's proprietary redundant ring technology, with recovery time of less 10/30 milliseconds and up to 250 nodes. The O-Ring redundant ring technology can protect mission-critical application from network interruptions or temporary malfunction with its fast recover technology.
 - NOTE 1.** Fast Ethernet ports supports less 10 milliseconds recovery time.
 - NOTE 2.** Gigabit Ethernet ports supports less 30 milliseconds recovery time.
- **O-Chain:** O-Chain is the revolutionary network redundancy technology that provides the add-on network redundancy topology for any backbone network, O-Chain allows multiple redundant network rings of different redundancy protocols to join and function together as a larger and more robust compound network topology. O-Chain providing ease-of-use while maximizing fault-recovery swiftness, flexibility, compatibility, and cost-effectiveness in one set of network redundancy topology.

- **MRP: Media Redundancy Protocol (MRP)** ^{*NOTE} is a data network protocol standardized by the IEC 62439-2. It allows rings of Ethernet switches to overcome any single failure with recovery time much faster than achievable with Spanning Tree Protocol.
- **Modbus TCP:** This is a Modbus variant used for communications over TCP/IP networks.

***NOTE: This function is available by request only**

Open-Vision

ORing's switches are intelligent switches. Different from other traditional redundant switches, ORing provides a set of Windows Utility (Open-Vision) for user to manage and monitor all of industrial Ethernet switches on the industrial network.

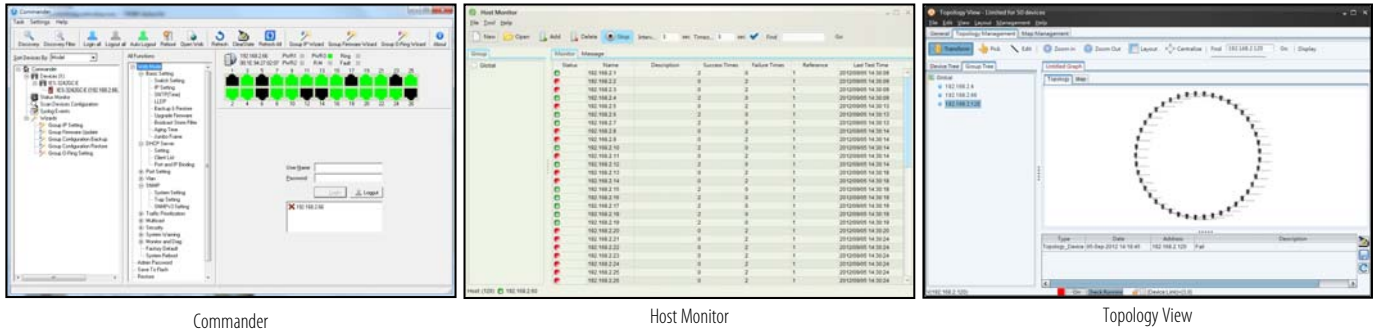

Dimensions

Unit=mm (Tolerance±0.5mm)

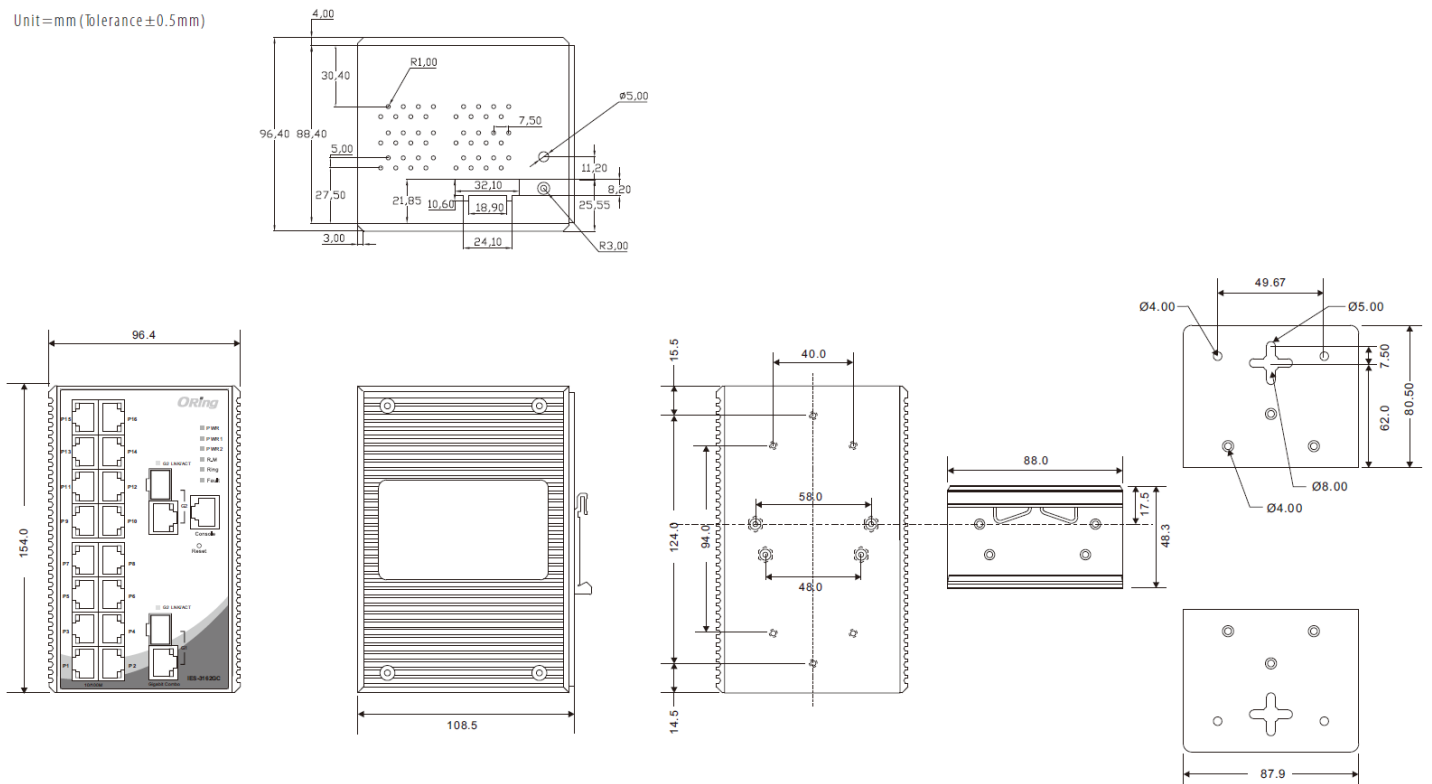

Specifications

| ORing Switch Model | IES-3162GC |
|---|---|
| Physical Ports | |
| 10/100Base-T(X) Ports in RJ45 Auto MDI/MDIX | 16 |
| Gigabit Combo Ports With 10/100/1000Base-T(X) and 100/1000Base-X SFP Port | 2 |
| Technology | |
| Ethernet Standards | IEEE 802.3 for 10Base-T IEEE 802.3u for 100Base-TX and 100Base-FX IEEE 802.3z for 1000Base-X IEEE 802.3ab for 1000Base-T IEEE 802.3x for Flow control IEEE 802.3ad for LACP (Link Aggregation Control Protocol) IEEE 802.1D for STP (Spanning Tree Protocol) IEEE 802.1p for COS (Class of Service) IEEE 802.1Q for VLAN Tagging IEEE 802.1w for RSTP (Rapid Spanning Tree Protocol) IEEE 802.1s for MSTP (Multiple Spanning Tree Protocol) IEEE 802.1x for Authentication IEEE 802.1AB for LLDP (Link Layer Discovery Protocol) |
| MAC Table | 8K |
| Packet Buffer Size | 1Mbits |
| Priority Queues | 4 |
| Processing | Store-and-Forward |
| Switch Properties | Switching latency: 2.28 us Switching bandwidth: 7.2Gbps Throughput (packet per second): 5.357Mpps@64Bytes packet Max. Number of Available VLANs: 4096 VLAN ID Range: VID 1 to 4095 IGMP multicast groups: 1024 Port rate limiting: User Define |
| Security Features | Enable/disable ports, MAC based port security Port based network access control (802.1x) VLAN (802.1Q) to segregate and secure network traffic Supports Q-in-Q VLAN for performance & security to expand the VLAN space Radius centralized password management SNMP V1/V2c/V3 encrypted authentication and access security |
| Software Features | STP/RSTP/MSTP (IEEE 802.1D/w/s) Redundant Ring (O-Ring) with recovery time less than 10/30ms over 250 units NOTE 1. Fast Ethernet ports supports less 10 milliseconds recovery time. NOTE 2. Gigabit Ethernet ports supports less 30 milliseconds recovery time. TOS/Diffserv supported Quality of Service (802.1p) for real-time traffic VLAN (802.1Q) with VLAN tagging and GVRP supported IGMP Snooping for multicast filtering Port configuration, status, statistics, monitoring, security SNTP for synchronizing of clocks over network Support PTP Client (Precision Time Protocol) clock synchronization DHCP Server / Client support Port Trunk support MVR (Multicast VLAN Registration) support Modbus TCP |
| Network Redundancy | O-Ring O-Chain MRP *NOTE MSTP/RSTP/STP |
| RS-232 Serial Console Port | RS-232 in RJ45 connector with console cable. 9600bps, 8, N, 1 |
| LED Indicators | |
| Power Indicator (PWR) | Green: Power LED x 3 |
| Ring Master Indicator (R.M.) | Green: Indicates that the system is operating in O-Ring Master mode |
| O-Ring Indicator (Ring) | Green: Indicates that the system operating in O-Ring mode Green Blinking: Indicates that the Ring is broken. |
| Fault Indicator (Fault) | Amber: Indicate unexpected event occurred |

*NOTE: This function is available by request only

| | |
|---|---|
| 10/100Base-T(X) RJ45 Port Indicator | Green for Link/Act indicator: On for link-up, Off for link-down, Blinking for act. Amber for Duplex/Collision indicator: On for full-duplex, Off for half-duplex, Blinking for half-duplex and collision occurred. |
| 10/100/1000Base-T(X) RJ45 Port Indicator (Combo Port) | Green for Link/Act indicator: On for link-up, Off for link-down, Blinking for act. Amber for 100Mbps indicator: On for 100Mbps, Off for 1000Mbps. |
| 100/1000Base-X SFP Port Indicator (Combo Port) | Green for Link/Act indicator: On for link-up, Off for link-down, Blinking for act. |
| Fault Contact | |
| Relay | Relay output to carry capacity of 1A at 24VDC |
| Reset Function | |
| Reset Button | < 5 sec: System reboot, > 5 sec: Factory default |
| Power | |
| Redundant Input Power | Dual DC inputs, 12~48VDC on 6-pin terminal block |
| Power Consumption (Typ.) | 15Watts, 12-48VDC/1.2A-0.3A |
| Overload Current Protection | Present |
| Reverse Polarity Protection | Present on terminal block |
| Physical Characteristic | |
| Enclosure | IP-30 Aluminum |
| Dimension (W x D x H) | 96.4 (W) x 108.5 (D) x 154 (H)mm 3.8 (W) x 4.27 (D) x 6.06 (H) inch |
| Weight (g) | 1220 g |
| Environmental | |
| Storage Temperature | -40 to 85°C (-40 to 185°F) |
| Operating Temperature | -40 to 75°C (-40 to 167°F) |
| Operating Humidity | 5% to 95% Non-condensing |
| Regulatory Approvals | |
| EMC | CE EMC (EN 55024, EN 55032), FCC Part 15 B |
| EMI | EN 55032, EN 61000-6-4, CISPR32, EN 61000-3-2, EN 61000-3-3, FCC Part 15 B class A |
| EMS | EN 55024 (IEC/EN 61000-4-2 (ESD: Contact 4KV, Air 8KV), IEC/EN 61000-4-3 (RS: 3V), IEC/EN 61000-4-4 (EFT Power 0.5KV, Signal 0.5KV), IEC/EN 61000-4-5 (Surge: Power 0.5KV, RJ45 1KV), IEC/EN 61000-4-6 (CS: 3V), IEC/EN 61000-4-8(PFME), IEC/EN 61000-4-11 (DIP)) EN 61000-6-2 (IEC/EN 61000-4-2 (ESD: Contact 4KV), IEC/EN 61000-4-3 (RS: 10V), IEC/EN 61000-4-4 (EFT Power 2KV, Signal 1KV), IEC/EN 61000-4-5 (Surge: Power 1KV, RJ45 1KV), IEC/EN 61000-4-6 (CS: 10V), IEC/EN 61000-4-8(PFME), IEC/EN 61000-4-11 (DIP)) |
| Shock | IEC60068-2-27 |
| Free Fall | IEC60068-2-31 |
| Vibration | IEC60068-2-6 |
| Safety | EN 62368-1 (LVD), UL 61010-1, UL 61010-2-201 |
| MTBF | 600504.1569 hrs. |
| Warranty | 5 years |

Ordering Information

IES-3AA B CC

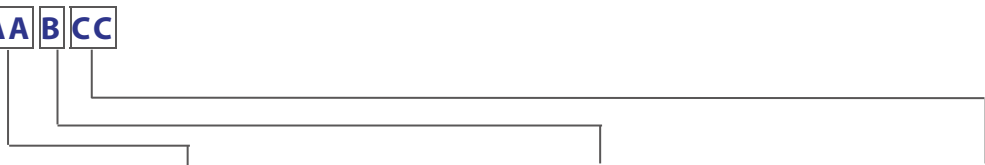

| Code Definition | 10/100Base-T(X) Port Number | Additional Port Number | Additional Port Type |
|-----------------|-----------------------------|------------------------|--------------------------------|
| Option | - 16: 16 ports | - 2: 2 ports | -GC: Gigabit combo port |

| Available Model | Model Name | Description |
|--|------------|--|
| | IES-3162GC | Industrial 18-port managed Ethernet switch with 16x10/100Base-T(X) and 2xGigabit combo ports, SFP socket |
| Packing List <ul style="list-style-type: none"> • IES-3162GC x 1 • DIN-Rail Kit x 1 • Wall-mount Kit x 2 • ORing Tool CD x 1 • Quick Installation Guide x 1 • Console Cable x 1 | | Optional Accessories <ul style="list-style-type: none"> • Open-Vision M500: Powerful Network Management Windows Utility Suit, 500 IP devices • SFP100 series: 100Mbps SFP optical transceiver • SFP 1G series: 1Gbps SFP optical transceiver • SDR/NDR Series DIN-Rail power supply |