

## Quick Installation Guide

## IPS-1080-24V

## Industrial Unmanaged PoE Switch

## Introduction





IPS-1080-24V is unmanaged PoE Ethernet switch with P.S.E. function. IPS-1080-24V supports Power over Ethernet, a system to transmit electrical power, along with data, to remote devices over standard twisted-pair cable in a network. IPS-1080-24V switch has 8X10/100Base-T(X) P.S.E. (Power Sourcing Equipment) ports. P.S.E. is a device (switch or hub for instance that will provide power in a PoE setup. The wide operating temperature range from -40°C to 75°C can satisfy most of operating environment. Therefore, the switch is one of the most reliable choices for PoE Ethernet application.

## Features

- > Provide 8x10/100Base-T(X) PoE (P.S.E.) ports
- > Supports IEEE 802.3at compliant PoE and total power budget is 120Watts with maximum 30Watts per port
- > Advanced PoE power boost technology to support dual 24VDC power inputs
- > Support auto-negotiation and auto-MDI/MDI-X
- > Support store and forward transmission
- > Support flow control
- > Warning system by relay output
- > Slim type rigid IP-30 housing design
- > DIN-Rail and wall mounting enabled

## Package Contents

The device is shipped with the following items. If any of these items is missing or damaged, please contact your customer service representative for assistance.



Contents	Pictures	Number
IPS-1080-24V		X 1
DIN-rail Kit		X 1
Wall-mount Kit		X 2
QIG		X 1
6-pin terminal block		X 1

## Preparation

Before you begin installing the switch, make sure you have all of the package contents available and a PC with Microsoft Internet Explorer 6.0 or later, for using web-based system management tools.

## Safety &amp; Warnings

-  **Elevated Operating Ambient:** If installed in a closed or multi-unit rack assembly, the operating ambient temperature of the rack environment may be greater than room ambient. Therefore, consideration should be given to installing the equipment in an environment compatible with the maximum ambient temperature (T<sub>ma</sub>) specified by the manufacturer.

-  **Reduced Air Flow:** Installation of the equipment in a rack should be such that the amount of air flow required for safe operation of the equipment is not compromised.
-  **Mechanical Loading:** Mounting of the equipment in the rack should be such that a hazardous condition is not achieved due to uneven mechanical loading.
-  **Circuit Overloading:** Consideration should be given to the connection of the equipment to the supply circuit and the effect that overloading of the circuits might have on overcurrent protection and supply wiring. Appropriate consideration of equipment nameplate ratings should be used when addressing this concern.

## Dimension Unit =mm (Tolerance ±0.5mm)

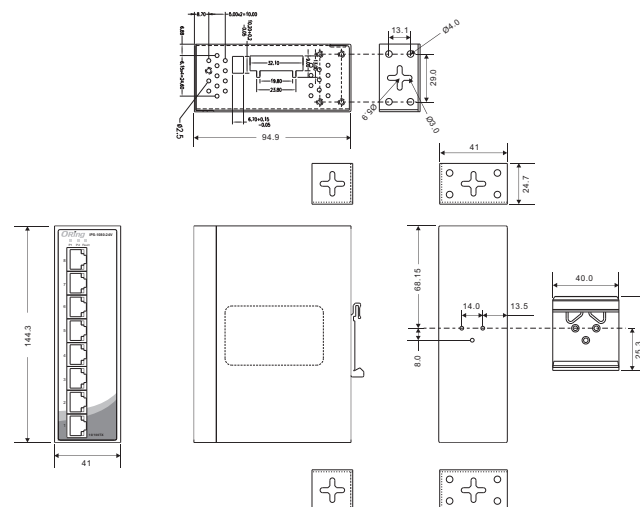

## Panel Layouts

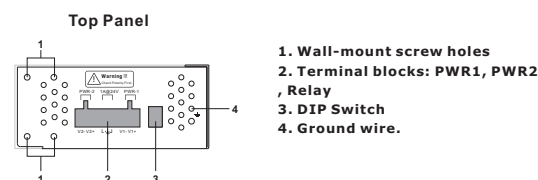
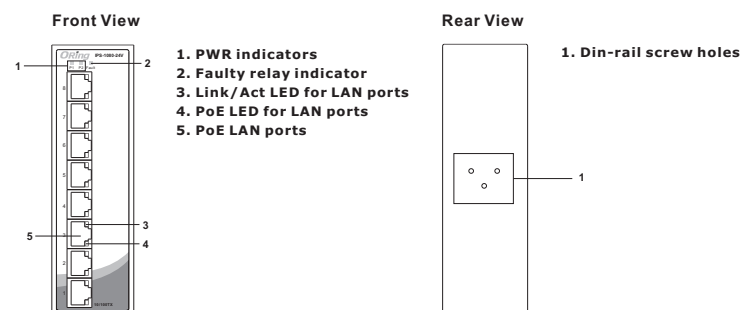

## Installation

## DIN-rail Installation

- Step 1:** Slant the switch and screw the Din-rail kit onto the back of the switch, right in the middle of the back panel.
- Step 2:** Slide the switch onto a DIN-rail from the Din-rail kit and make sure the switch clicks into the rail firmly.

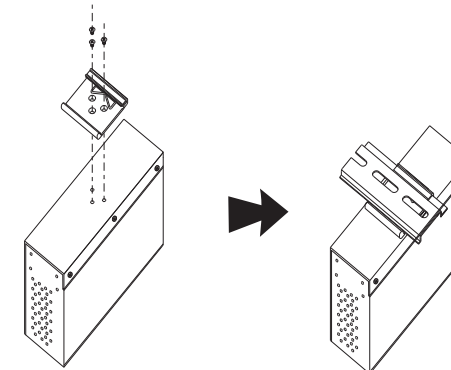

## Wall-mounting

- Step 1:** Screw the wall-mount kit onto the rear panel of the switch. A total of six screws are required, as shown below.
- Step 2:** Use the switch, with wall mount plates attached, as a guide to mark the correct locations of the four screws.
- Step 3:** Insert a screw head through the large parts of the keyhole-shaped apertures, and then slide the switch downwards. Tighten the screws for added stability.

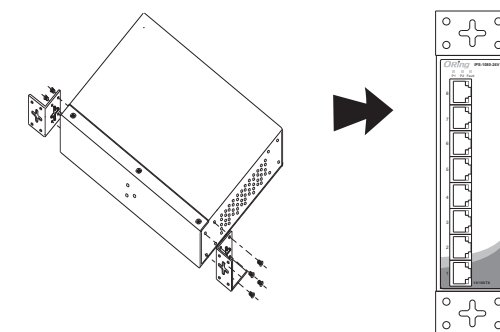

## Network Connection

The switch provides standard Ethernet ports. According to the link type, the switch uses CAT 3,4,5,5e UTP cables to connect to any other network devices (PCs, servers, switches, routers, or hubs). Please refer to the following table for cable specifications.

## Cable Types and Specifications:

Cable	Type	Max. Length	Connector
10BASE-T	Cat. 3, 4, 5 100-ohm	UTP 100 m (328 ft)	RJ-45
100BASE-TX	Cat. 5 100-ohm UTP	UTP 100 m (328 ft)	RJ-45

For pin assignments for different types of cables, please refer to the following tables.

10/100Base-T(X) P.S.E. RJ-45 port	
Pin No.	Description
#1	TD+ with PoE Power Input +
#2	TD- with PoE Power Input +
#3	RD+ with PoE Power Input -
#4	N.C.
#5	N.C.
#6	RD- with PoE Power Input -
#7	N.C.
#8	N.C.

Note: "+" and "-" signs represent the polarity of the wires that make up each wire pair.

#### DIP Switch Setting

DIP-1	DIP-2	Description
OFF	OFF	Power failure relay alarm disabled
ON	OFF	PWR-1 failure, relay alarm enabled
OFF	ON	PWR-2 failure, relay alarm enabled
ON	ON	PWR-1 or PWR-2 failure, relay alarm enabled

#### Wiring

##### Power inputs

The switch supports dual redundant power supplies, Power Supply 1 (PWR1) and Power Supply 2 (PWR2). The connections for PWR1, PWR2 and the RELAY are located on the terminal block.

**STEP 1:** Insert the negative/positive wires into the V-/V+ terminals, respectively.

**STEP 2:** To keep the DC wires from pulling loose, use a small flat-blade screwdriver to tighten the wire-clamp screws on the front of the terminal block connector.

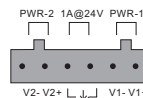

##### Relay contact

The two sets of relay contacts of the 6-pin terminal block connector are used to detect user-configured events. The two wires attached to the fault contacts form an close circuit when a user-configured event is triggered. If a user-configured event does not occur, the fault circuit remains opened.

##### Grounding

Grounding and wire routing help limit the effects of noise due to electromagnetic interference (EMI). Run the ground connection from the ground screws to the grounding surface prior to connecting devices.

#### Configurations

After installing the switch, the green power LED should turn on. Please refer to the following table for LED indication.

LED	Color	Status	Description
P1	Green	On	DC power 1 activated
P2	Green	On	DC power 2 activated
Fault	Amber	On	Faulty relay (power failure or port disconnected)
10/100/1000Base-T(X) Gigabit PoE Ethernet ports			
LNK/ACT	Green	On	Port link at 10/100Mbps
PoE	Green	On	Power supplied over Ethernet

#### Specifications

ORing Switch Model	IPS-1080-24V
<b>Physical Ports</b>	
10/100 Base-T(X) Ports in RJ45 Auto MDI/MDIX with P.S.E.	8
<b>Technology</b>	
Ethernet Standards	IEEE 802.3 for 10Base-T IEEE 802.3u for 100Base-TX IEEE 802.3x for Flow control IEEE 802.3at PoE specification (total power budget is 120Watts with maximum 30Watts per port)
MAC Table	1K MAC addresses
Processing	Store-and-Forward
Switch Latency	<7us
Switch Bandwidth	16Gbps
Packet buffer size	448K bits
<b>LED Indicators</b>	
Power indicator	Green: Power LED x2
Fault indicator	Amber: Indicate PWR1 or PWR2 failure
10/100Base-T(X)RJ45 Port Indicator	Green for port Link/Act. Green for PoE power injected.
<b>DIP-Switch</b>	
DIP-Switch 1	Power-2 failed warning: (ON) enable, (OFF) disable
DIP-Switch 2	Power-1 failed warning: (ON) enable, (OFF) disable
<b>Fault Contact</b>	
Relay	Relay output to carry capacity of 1A at 24 VDC
<b>Power</b>	
Redundant Input power	Dual DC Inputs 12~57VDC on 6-pin terminal block
Power consumption(Typ.)	3 Watts (PoE output not included)
PoE Power budget	60W at 12~24VDC, 120W at 24~57VDC
Overload current protection	Present
Reverse polarity protection	Present
<b>Physical Characteristic</b>	
Enclosure	IP-30, Metal
Dimension (W x D x H)	41 (W) x 94.9 (D) x 144.3 (H) mm (1.03 x 3.74 x 5.68 inches)
Weight (g)	634g
<b>Environmental</b>	
Storage Temperature	-40 to 85°C (-40 to 185°F)
Operating Temperature	-40 to 75°C (-40 to 158°F)
Operating Humidity	5% to 95% Non-condensing
<b>Regulatory Approvals</b>	
EMC	CE EMC (EN 55024, EN 55032), FCC Part 15B
EMI	EN 55032, CISPR32, EN 61000-3-2, EN 61000-3-3, FCC Part 15B class A
EMS	EN 55024 (IEC/EN 61000-4-2 (ESD), IEC/EN 61000-4-3 (RS), IEC/EN 61000-4-4 (EFT), IEC/EN 61000-4-5 (Surge), IEC/EN 61000-4-6 (CS), IEC/EN 61000-4-8 (PFMF), IEC/EN 61000-4-11 (DIP))
Shock	IEC60068-2-27
Free Fall	IEC60068-2-31
Vibration	IEC60068-2-6
Safety	UL 60950-1, CSA C22.2 No. 60950-1-07, EN 60950-1, IEC 60950-1
MTBF	744974hrs
Warranty	5 years

Note : HW version 5.0

Copyright© 2011 ORing  
All rights reserved.



**ORing Industrial Networking Corp.**  
TEL: +886-2-2218-1066 Website: www.oringnet.com  
FAX: +886-2-2218-1014 E-mail: support@oringnet.com