

#### Introduction

**IGS-182GP** is unmanaged Ethernet switch with 8x10/100/1000Base-T(X) with 2x100/1000Base-X ports. With very compact size of housing, you can install **IGS-182GP** easily. In addition, **IGS-182GP** is with rigid IP-30 housing design and can operate under harsh environment. The extended operating temperature range from -40°C to 75°C is ready and can satisfy most requirement of operation.

The product is open type, intended to be installed in and industrial control panel or an enclosure.

#### Package Contents

The device is shipped with the following items. If any of these items is missing or damaged, please contact your customer service representative for assistance.

Contents	Pictures	Number
IGS-182GP		X 1
DIN-rail Kit		X 1
Wall-mount Kit		X 2
QIG		X 1
4-pin terminal block		X 1

#### Preparation

Before you begin installing the switch, make sure you have all of the package contents available.

##### Safety & Warnings

- Elevated Operating Ambient:** If installed in a closed cabinet, the operating ambient temperature of the rack environment may be greater than room ambient. Therefore, consideration should be given to installing the equipment in an environment compatible with the maximum ambient temperature (T<sub>ma</sub>) specified by the manufacturer.
- Reduced Air Flow:** Installation of the equipment should be such that the amount of air flow required for safe operation of the equipment is not compromised.
- Mechanical Loading:** Mounting of the equipment in the din-rail should be such that a hazardous condition is not achieved due to uneven mechanical loading.
- Circuit Overloading:** Consideration should be given to the connection of the equipment to the supply circuit and the effect that overloading of the circuits might have on overcurrent protection and supply wiring. Appropriate consideration of equipment nameplate ratings should be used when addressing this concern.



- \* Indoor use and pollution degree II, it must be wiped with a dry cloth for clean up the device and label.
- \* Utilisation en intérieur et degré de pollution II, il faut l'essuyer avec un chiffon sec pour nettoyer l'appareil et son étiquette.
- \* Do not block air ventilation holes.
- \* Ne bouchez pas les orifices de ventilation.
- \* If the equipment is used in a manner not specified by the manufacturer, the protection provided by the equipment may be impaired.
- \* Si l'appareil est utilisé d'une manière non spécifiée par le fabricant, la protection qu'il apporte peut se voir diminuée.
- \* Shall be mounted in the Industrial Control Panel and ambient temperature is not exceed 75 degree C
- \* doit être monté dans le panneau de commande industriel et la température ambiante ne doit pas dépasser 75 degrés C

##### Dimension Unit =mm (Tolerance ±0.5mm)

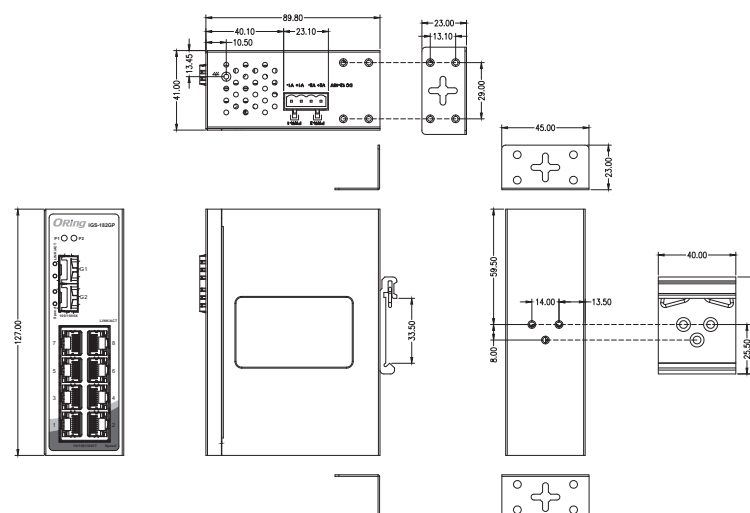

##### Panel Layouts

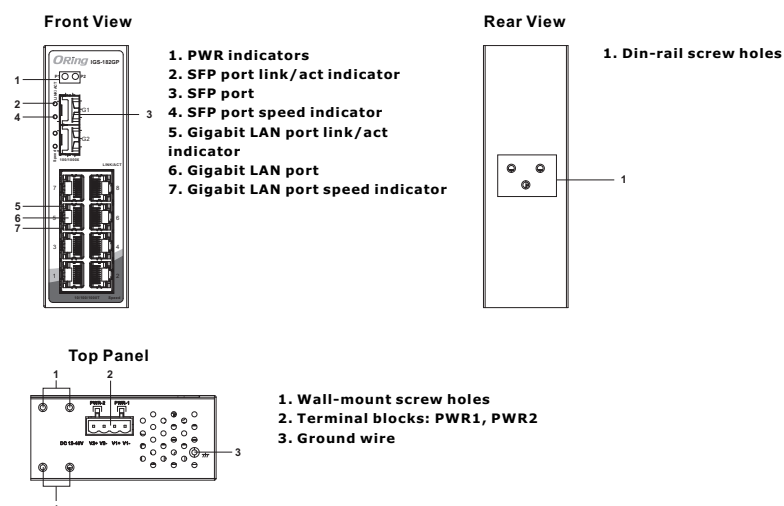

#### Installation

##### DIN-rail Installation

- Step 1:** Slant the switch and screw the Din-rail kit onto the back of the switch, right in the middle of the back panel.
- Step 2:** Slide the switch onto a DIN-rail from the Din-rail kit and make sure the switch clicks into the rail firmly.

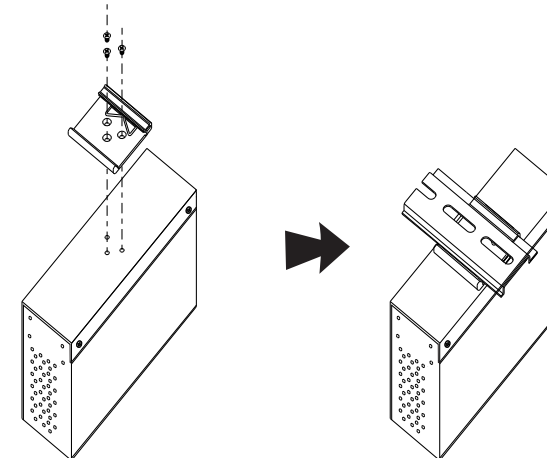

##### Wall-mounting

- Step 1:** Screw the wall-mount kit onto the rear panel of the switch. A total of six screws are required, as shown below.
- Step 2:** Use the switch, with wall mount plates attached, as a guide to mark the correct locations of the four screws.
- Step 3:** Insert a screw head through the large parts of the keyhole-shaped apertures, and then slide the switch downwards. Tighten the screws for added stability.

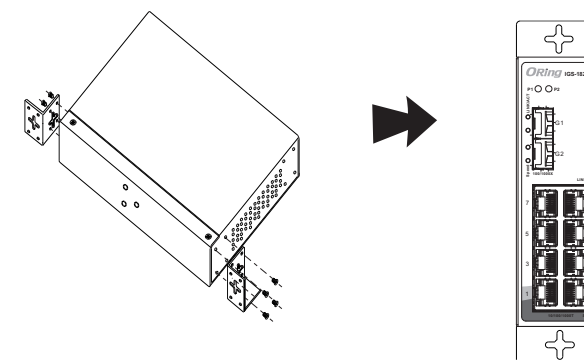

##### Warning [AVERTISSEMENT]

- Take into consideration the following guidelines before wiring the device  
[Tenez compte des directives suivantes avant de câbler l'appareil.]
1. Terminal block is mating with Plug and suitable for 12-24AWG. Torque value 4.5 lb-in. [Le bornier est compatible avec les connecteurs et convient pour 12-24AWG. Valeur de couple 4,5 lb-in.]
  2. The temperature rating of the input connection cable should higher than 105°C [La température de service nominale du câble d'entrée doit être supérieure à 105 °C]
  3. Use Copper Conductors Only. [Utilisez uniquement des conducteurs en cuivre.]

### Network Connection

The device has standard gigabit Ethernet ports. According to the link type, the switch uses CAT 3, 4, 5, 5e UTP cables to connect to any other network devices (PCs, servers, switches, routers, or hubs). Please refer to the following table for cable specifications.

#### Cable Types and Specifications:

Cable	Type	Max. Length	Connector
10BASE-T	Cat. 3, 4, 5 100-ohm	UTP 100 m (328 ft)	RJ-45
100BASE-TX	Cat. 5 100-ohm UTP	UTP 100 m (328 ft)	RJ-45
1000BASE-T	Cat. 5 / Cat. 5e 100-ohm UTP	UTP 100 m (328 ft)	RJ-45

For pin assignments for different types of cables, please refer to the following tables.

1000Base-T RJ-45 Port		10/100 Base-T(X) RJ-45 Port	
Pin Number	Assignment	Pin Number	Assignments
1	BI_DA+	1	TD+
2	BI_DA-	2	TD-
3	BI_DB+	3	RD+
4	BI_DC+	4	Not used
5	BI_DC-	5	Not used
6	BI_DB-	6	RD-
7	BI_DD+	7	Not used
8	BI_DD-	8	Not used

10/100 Base-T(X) MDI/MDI-X			1000Base-T MDI/MDI-X		
Pin Number	MDI port	MDI-X port	Pin Number	MDI port	MDI-X port
1	TD+(transmit)	RD+(receive)	1	BI_DA+	BI_DB+
2	TD-(transmit)	RD-(receive)	2	BI_DA-	BI_DB-
3	RD+(receive)	TD+(transmit)	3	BI_DB+	BI_DA+
4	Not used	Not used	4	BI_DC+	BI_DD+
5	Not used	Not used	5	BI_DC-	BI_DD-
6	RD-(receive)	TD-(transmit)	6	BI_DB-	BI_DA-
7	Not used	Not used	7	BI_DD+	BI_DC+
8	Not used	Not used	8	BI_DD-	BI_DC-

Note: "+" and "-" signs represent the polarity of the wires that make up each wire pair.

### Wiring

#### Power inputs

The switch supports dual redundant power supplies which are located on the 4-pin terminal block.

**STEP 1:** Insert the negative/positive wires into the V-/V+ terminals, respectively.

**STEP 2:** To keep the DC wires from pulling loose, use a small flat-blade screwdriver to tighten the wire-clamp screws on the front of the terminal block connector.



#### Grounding

Grounding and wire routing help limit the effects of noise due to electromagnetic interference (EMI). Run the ground connection from the ground screws to the grounding surface prior to connecting devices.

### Configurations

After installing the device and connecting cables, start the switch by turning on power. The green power and LEDs should turn on.

### LED indication table

LED	Color	Status	Description
P1	Green	On	DC power module 1 activated
P2	Green	On	DC power module 2 activated
SFP ports			
LNK/ACT	Green	On	Port is linked
		Blinking	Transmitting data
Speed	Green	On	Port link at 1000Mbps
		Amber	Port link at 100Mbps
10/100/1000Base-T(X) Ethernet ports			
LNK/ACT	Green	On	Port is linked
		Blinking	Transmitting data
Speed	Green	On	Port link at 1000Mbps
		Amber	Port link at 100Mbps
		Green/Amber	Port link at 10Mbps

### Specifications

ORing Switch Model	IGS-182GP
<b>Physical Ports</b>	
10/100/1000Base-T(X) Ports in RJ45 Auto MDI/MDIX	8
100/1000Base-X ports	2
<b>Technology</b>	
Ethernet Standards	IEEE 802.3 for 10Base-T IEEE 802.3u for 100Base-TX and 100Base-FX IEEE 802.3ab for 1000Base-T IEEE 802.3z for 1000Base-X IEEE 802.3x for Flow control
MAC Table	4K
Processing	Store-and-Forward
Switch Latency	<7us
Switching bandwidth	20G bps
Packet buffer	1.5M bits
Jumbo Frame	9216 Bytes
<b>Power</b>	
Input power	Dual 12~48 VDC voltage power input on 4-pin terminal block * Supplied by SELV or double insulation source evaluated by UL 61010-1 or 61010-2-201 power supply only. * Fourni par la source SELV ou double isolation évaluée uniquement par l'alimentation UL 61010-1 or 61010-2-201.
Power consumption(Typ.)	<5Watts, 12-48VDC: 0.41A-0.11A
Overload current protection	Present
Reverse polarity protection	Present
<b>Physical Characteristic</b>	
Dimension (W x D x H)	41(W) x 89.8 (D) x 127 (H)mm (1.61x 3.54 x 5inch.)
Weight (g)	400 g
<b>Environmental</b>	

Storage Temperature	-40 to 85°C (-40 to 185°F)
Operating Temperature	-40 to 75°C (-40 to 167°F)
Operating Humidity	5% to 95% Non-condensing
Operating Altitude	Up to 2000m
<b>Regulatory Approvals</b>	
EMC	CE EMC (EN 55024, EN 55032), FCC Part 15 B
EMI	EN 55032, CISPR32, EN 61000-3-2, EN 61000-3-3, FCC Part 15 B class A
EMS	EN 55024 (IEC/EN 61000-4-2 (ESD: Contact 4KV, Air 8KV), IEC/EN 61000-4-3 (RS: 3V), IEC/EN 61000-4-4 (EFT Power 0.5KV, Signal 0.5KV), IEC/EN 61000-4-5 (Surge: Power 0.5KV, RJ45 1KV), IEC/EN 61000-4-6 (CS: 3V), IEC/EN 61000-4-8(PFMF), IEC/EN 61000-4-11 (DIP)
Shock	IEC60068-2-27
Free Fall	IEC60068-2-31
Vibration	IEC60068-2-6
Safety	UL61010-1, UL61010-2-201
MTBF	1056,516 hours
Warranty	5 years

#### Contact for maintenance and repair service:

Copyright© 2020 ORing  
All rights reserved.



#### ORing Industrial Networking Corp.

TEL: +886-2-2218-1066 Website: www.oringnet.com  
FAX: +886-2-2218-1014 E-mail: support@oringnet.com  
Address: 3F., No. 542-2, Zhongzheng Rd., Xindian Dist., New Taipei City 23148, Taiwan