

## Quick Installation Guide

## IGPS-1080-24V

## Industrial Unmanaged Gigabit PoE Switch

## Introduction





**IGPS-1080-24V** is an unmanaged Gigabit PoE Ethernet switch with P.S.E. function. **IGPS-1080-24V** supports Power over Ethernet, a system to transmit electrical power, along with data, to remote devices over standard twisted-pair cable in an Ethernet network. **IGPS-1080-24V** supports wide range 12~57VDC(24 VDC for Vehicle use) power inputs and generates 50VDC P.S.E. power output per port. **IGPS-1080-24V** PoE switch has 8X10/100/1000Base-T(X) P.S.E. (Power Sourcing Equipment) ports. P.S.E. is a device (switch or hub for instance) that will provide power in a PoE setup. The wide operating temperature range from -40°C to 70°C can satisfy most of operating environment. Therefore, the switch is one of the most reliable choices for PoE Ethernet application. The product is open type, intended to be installed in and industrial control panel or an enclosure. It is designed to be installed on a moving transportation system.

## Features

- > **IGPS-1080-24V** provide 8x10/100/100Base-T(X) PoE (P.S.E.) ports
- > Support IEEE 802.3at compliant PoE and total power budget is 120Watts with maximum 30Watts per port
- > Supports jumbo frame up to 9KBytes
- > Support dual wide range 12~57VDC(24VDC for Vehicle use)power inputs for power redundancy
- > Support auto-negotiation and auto-MDI/MDI-X
- > Support store and forward transmission
- > Support flow control
- > Rigid IP-30 housing design (non UL certified)
- > DIN-Rail and wall mounting enabled

## Package Contents

The device is shipped with the following items. If any of these items is missing or damaged, please contact your customer service representative for assistance.



Contents	Pictures	Number
IGPS-1080-24V		X 1
DIN-rail Kit		X 1
Wall-mount Kit		X 2
QIG		X 1
6-pin terminal block		X 1

## Preparation

Before you begin installing the switch, make sure you have all of the package contents available and a PC with Microsoft Internet Explorer 6.0 or later, for using web-based system management tools.

## Safety &amp; Warnings

-  **Elevated Operating Ambient:** If installed in a closed or multi-unit rack assembly, the operating ambient temperature of the rack environment may be greater than room ambient. Therefore, consideration should be given to installing the equipment in an environment compatible with the maximum ambient temperature (T<sub>ma</sub>) specified by the manufacturer.

-  **Reduced Air Flow:** Installation of the equipment in a rack should be such that the amount of air flow required for safe operation of the equipment is not compromised.
-  **Mechanical Loading:** Mounting of the equipment in the rack should be such that a hazardous condition is not achieved due to uneven mechanical loading.
-  **Circuit Overloading:** Consideration should be given to the connection of the equipment to the supply circuit and the effect that overloading of the circuits might have on overcurrent protection and supply wiring. Appropriate consideration of equipment nameplate ratings should be used when addressing this concern.

## Dimension Unit =mm (Tolerance ±0.5mm)

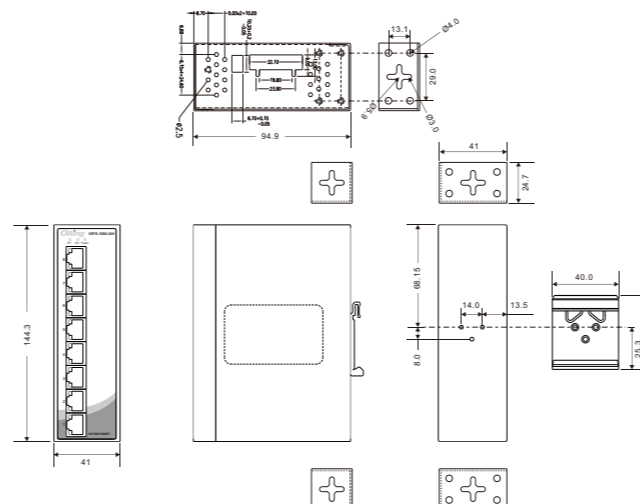

## Panel Layouts

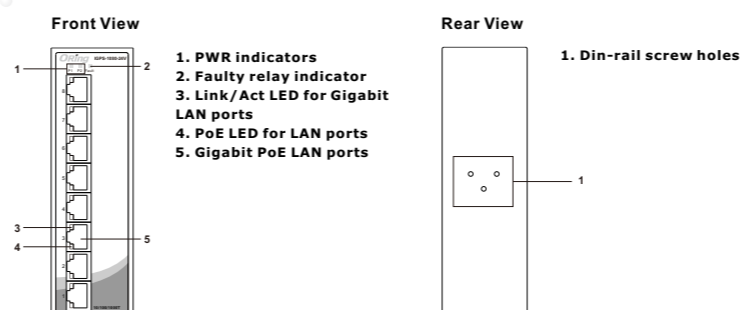

## Installation

## DIN-rail Installation

- Step 1:** Slant the switch and screw the Din-rail kit onto the back of the switch, right in the middle of the back panel.
- Step 2:** Slide the switch onto a DIN-rail from the Din-rail kit and make sure the switch clicks into the rail firmly.

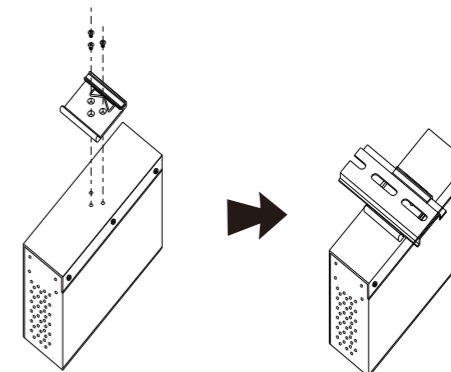

## Wall-mounting

- Step 1:** Screw the wall-mount kit onto the rear panel of the switch. A total of six screws are required, as shown below.
- Step 2:** Use the switch, with wall mount plates attached, as a guide to mark the correct locations of the four screws.
- Step 3:** Insert a screw head through the large parts of the keyhole-shaped apertures, and then slide the switch downwards. Tighten the screws for added stability.

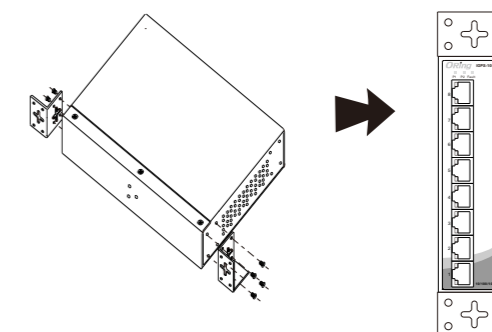

## Network Connection

The switch provides standard Ethernet ports. According to the link type, the switch uses CAT 3,4,5,6 UTP cables to connect to any other network devices (PCs, servers, switches, routers, or hubs). Please refer to the following table for cable specifications.

## Cable Types and Specifications:

Cable	Type	Max. Length	Connector
10BASE-T	Cat. 3, 4, 5 100-ohm	UTP 100 m (328 ft)	RJ-45
100BASE-TX	Cat. 5 100-ohm UTP	UTP 100 m (328 ft)	RJ-45
1000BASE-T	Cat. 5 / Cat. 5e 100-ohm UTP	UTP 100 m (328 ft)	RJ-45

For pin assignments for different types of cables, please refer to the following tables.

10/100Base-T(X) PSE RJ-45 port		1000Base-T PSE RJ-45 port	
Pin No.	Description	Pin No.	Description
#1	TD+ with PoE Power Input +	#1	BI_DA+ with PoE Power Input +
#2	TD- with PoE Power Input +	#2	BI_DA- with PoE Power Input +
#3	FD+ with PoE Power Input -	#3	BI_DB+ with PoE Power Input -
#4	NC	#4	BI_DC-
#5	NC	#5	BI_DC-
#6	FD- with PoE Power Input -	#6	BI_DB- with PoE Power Input -
#7	NC	#7	BI_DD+
#8	NC	#8	BI_DD-

Note: "+" and "-" signs represent the polarity of the wires that make up each wire pair.

#### DIP Switch Setting

DIP-1	DIP-2	Description
OFF	OFF	Power failure relay alarm disabled
ON	OFF	PWR-1 failure, relay alarm enabled
OFF	ON	PWR-2 failure, relay alarm enabled
ON	ON	PWR-1 or PWR-2 failure, relay alarm enabled

#### Wiring

##### Power inputs

The switch supports dual redundant power supplies, Power Supply 1 (PWR1) and Power Supply 2 (PWR2). The connections for PWR1, PWR2 and the RELAY are located on the terminal block.

**STEP 1:** Insert the negative/positive wires into the V-/V+ terminals, respectively.

**STEP 2:** To keep the DC wires from pulling loose, use a small flat-blade screwdriver to tighten the wire-clamp screws on the front of the terminal block connector.

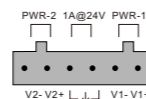

##### Relay contact

The two sets of relay contacts of the 6-pin terminal block connector are used to detect user-configured events. The two wires attached to the fault contacts form an open circuit when a user-configured event is triggered. If a user-configured event does not occur, the fault circuit remains open.

##### Grounding

Grounding and wire routing help limit the effects of noise due to electromagnetic interference (EMI). Run the ground connection from the ground screws to the grounding surface prior to connecting devices.

#### Configurations

After installing the switch, the green power LED should turn on. Please refer to the following table for LED indication.

LED	Color	Status	Description
P1	Green	On	DC power 1 activated
P2	Green	On	DC power 2 activated
Fault	Amber	On	Faulty relay (power failure or port disconnected)
10/100/1000Base-T(X) Gigabit PoE Ethernet ports			
LNK/ACT	Green	On	Port link at 1000Mbps
	Amber	On	Port link at 10/100Mbps
PoE	Green	On	Power supplied over Ethernet

#### Specifications

ORing Switch Model	IGPS-1080-24V
<b>Physical Ports</b>	
10/100/1000Base-T(X) P.S.E. Port in RJ45 Auto MDI/MDIX	8
<b>Technology</b>	
Ethernet Standards	IEEE 802.3 for 10Base-T IEEE 802.3u for 100Base-TX IEEE 802.3ab for 1000Base-T IEEE 802.3x for Flow control IEEE 802.3at PoE specification
MAC Table	4K
Packet buffer	1.5Mbits
Processing	Store-and-Forward
Jumbo Frame	9720 Bytes
Switch Properties	Switching latency: 7 μs Switching bandwidth: 16Gbps Throughput (packet per second) : 11.58Mpps@64Bytes packet
<b>LED Indicators</b>	
Power indicator	Green: Power LED x2
Fault indicator	Amber: Indicate PWR1 or PWR2 failure
10/100/1000Base-T(X) RJ45 port Indicator and PoE indicator	Green for port Link/Act at 1000Mbps / Amber for port Link/Act at 10/100Mbps Green for PoE power injected
<b>DIP-Switch</b>	
DIP-Switch 1	Power-1 failed warning : (ON) enable, (OFF) disable
DIP-Switch 2	Power-2 failed warning : (ON) enable, (OFF) disable
<b>Fault contact</b>	
Relay	Relay output to carry capacity of 1A at 24 VDC
<b>Power</b>	
Redundant Input power	Dual DC inputs 12-57VDC(24VDC for Vehicle use) on 6-pin terminal block * Supplied by SELV or double insulation source evaluated by UL 61010-1 or 61010-2-201 power supply only. * Fourni par la source SELV ou double isolation évaluée uniquement par l'alimentation UL 61010-1 or 61010-2-201.
PoE output power	60 Watts at 12 to 24VDC, 120 Watts at 24.1 to 57VDC
Power consumption(Typ.)	5.4A at 12VDC, 2.7A at 24VDC, 2.2A at 57VDC
Overload current protection	Present
Reverse polarity protection	Present
<b>Physical Characteristic</b>	
Enclosure	IP-30 (non UL certified)
Dimension (W x D x H)	41(W)x94.9(D)x144.3(H) mm (1.62x3.74x5.68inch.)
Weight (g)	643 g
<b>Environmental</b>	
Storage Temperature	-40 to 85°C (-40 to 185°F)
Operating Temperature	-40 to 70°C (-40 to 158°F)
Operating Humidity	5% to 95% Non-condensing
Operating Altitude	Up to 2000m
<b>Regulatory Approvals</b>	
EMC	CE EMC (EN 55035, EN 55032), FCC Part 15 B
EMI	EN 55032, CISPR32, FCC Part 15 B class A
EMS	EN 55035 (IEC/EN 61000-4-2(ESD), IEC/EN 61000-4-3 (RS), IEC/EN 61000-4-4(EFT), IEC/EN 61000-4-5 (Surge), IEC/EN 61000-4-6 (CS), IEC/EN 61000-4-8(PFME), IEC/EN 61000-4-11(DIP))
Shock	IEC 60068-2-27

Free Fall	IEC 60068-2-31
Vibration	IEC 60068-2-6
Safety	UL 61010-1, UL 61010-2-201
MTBF	532,527 hours / Standard : Telcordia SR-332
Warranty	5 years



#### Warning [AVERTISSEMENT]

Take into consideration the following guidelines before wiring the device [Tenez compte des directrices suivantes avant de câbler l'appareil.]

- Terminal block is mating with Plug and suitable for 12-18AWG. Torque value 4.5 lb-in. [Le bornier est compatible avec les connecteurs et convient pour 12-18AWG. Valeur de couple 4,5 lb-in.]
- The temperature rating of the input connection cable should higher than 105°C [La température de service nominale du câble d'entrée doit être supérieure à 105 °C]
- Use Copper Conductors Only. [Utilisez uniquement des conducteurs en cuivre.]

- \* Indoor use and pollution degree II, it must be wiped with a dry cloth for clean up the device and label.
- \* Utilisation en intérieur et degré de pollution II, il faut l'essuyer avec un chiffon sec pour nettoyer l'appareil et son étiquette.
- \* Do not block air ventilation holes.
- \* Ne blochez pas les orifices de ventilation.
- \* If the equipment is used in a manner not specified by the manufacturer, the protection provided by the equipment may be impaired."
- \* Si l'appareil est utilisé d'une manière non spécifiée par le fabricant, la protection qu'il apporte peut se voir diminuée."
- \* Shall be mounted in the Industrial Control Panel and ambient temperature is not exceed 70 degree C
- \* doit être monté dans le panneau de commande industriel et la température ambiante ne doit pas dépasser 70 degrés C



#### Warning. Hot Surface AVERTISSEMENT : SURFACE(S) CHAUDE(S)

#### Application section

The unmanaged Gigabit PoE Ethernet switch is equipped with P.S.E capability. It is designed for data communication within vehicles, to facilitate data transfer to the operation center, and to offer Ethernet connectivity and expandability. It's important to note that these features have no impact on the safety of driving and passenger well-being and the device does not possess any immunity-related functionalities.

Contact for maintenance and repair service:

**ORing**

Copyright© 2024 ORing  
All rights reserved.

---

**ORing Industrial Networking Corp.**

TEL: +886-2-2218-1066 Website: www.oringnet.com  
FAX: +886-2-2218-1014 E-mail: support@oringnet.com  
Address: 3F., No.542-2, Zhongzheng Rd., Xindian Dist., New Taipei City 23148, Taiwan