

# Quick Installation Guide

## IES-3240

## Industrial Managed Ethernet Switch

### Introduction

**IES-3240** is managed Redundant Ring Ethernet switch with 24x10/100Base-T(X) ports. With completely support of Ethernet Redundancy protocol, O-Ring (recovery time < 10ms over 250 units of connection), O-Chain, MRP\***NOTE** and MSTP/RSTP/STP (IEEE 802.1s/w/D) can protect your mission-critical applications from network interruptions or temporary malfunctions with its fast recovery technology. O-Chain is the revolutionary network redundancy technology that provides the add-on network redundancy topology for any backbone network, O-Chain allows multiple redundant network rings of different redundancy protocols to join and function together as a larger and more robust compound network topology. O-Chain providing ease-of-use while maximizing fault-recovery swiftness, flexibility, compatibility, and cost-effectiveness in one set of network redundancy topology. All function of **IES-3240** can be managed centralized and convenient by a powerful windows utility — Open-Vision. In addition, the wide operating temperature range from -40 to 75°C can satisfy most of operating environment. Therefore, the switch is one of the most reliable choice for highly-managed Ethernet application.

The product is open type, intended to be installed in and industrial control panel or an enclosure.

**\*NOTE : This function is available by request only.**

### Package Contents

The device is shipped with the following items. If any of these items is missing or damaged, please contact your customer service representative for assistance.

Contents	Pictures	Number
IES-3240		X 1
CD		X 1
DIN-rail Kit		X 1
Wall-mount Kit		X 2
Console Cable		X 1
QIG		X 1

### Preparation

Before you begin installing the switch, make sure you have all of the package contents available and a PC with Microsoft Internet Explorer 6.0 or later, for using web-based system management tools.

#### Safety & Warnings

**Elevated Operating Ambient:** If installed in a closed or multi-unit rack assembly, the operating ambient temperature of the rack environment may be greater than room ambient. Therefore, consideration should be given to installing the equipment in an environment compatible with the maximum ambient temperature (T<sub>ma</sub>) specified by the manufacturer.

**Reduced Air Flow:** Installation of the equipment in a rack should be such that the amount of air flow required for safe operation of the equipment is not compromised.

- Mechanical Loading:** Mounting of the equipment in the rack should be such that a hazardous condition is not achieved due to uneven mechanical loading.
- Circuit Overloading:** Consideration should be given to the connection of the equipment to the supply circuit and the effect that overloading of the circuits might have on overcurrent protection and supply wiring. Appropriate consideration of equipment nameplate ratings should be used when addressing this concern.

Dimension Unit =mm (Tolerance ±0.5mm)

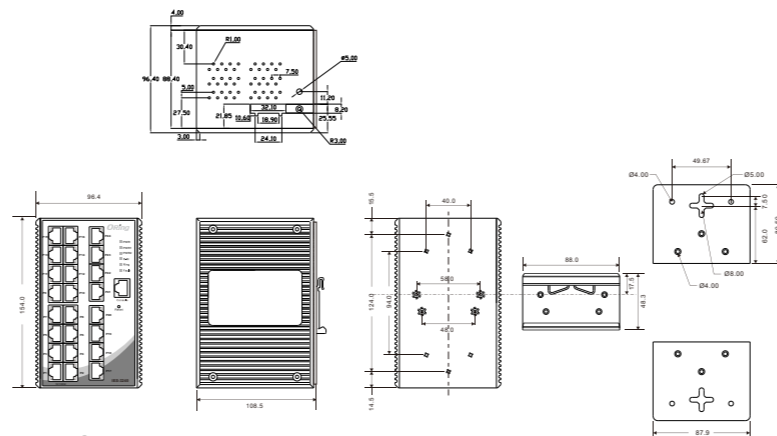

#### Panel Layouts

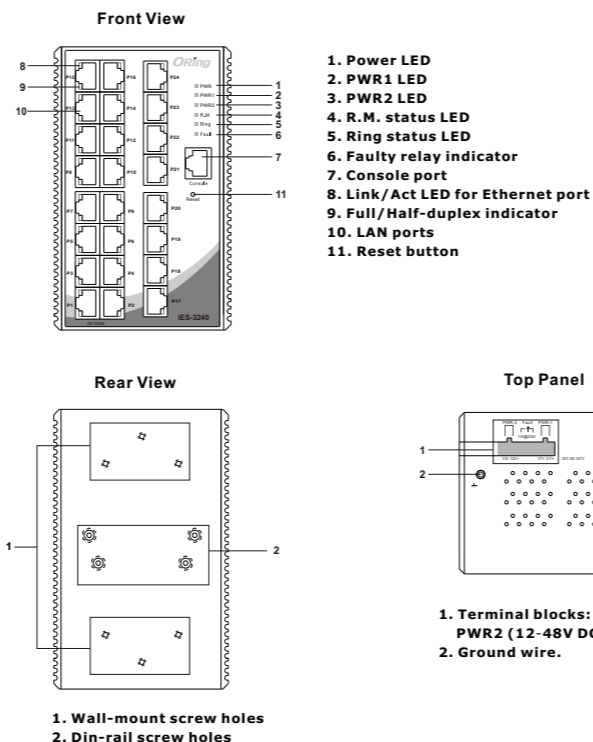

### Installation

#### DIN-rail Installation

**Step 1:** Slant the switch and screw the Din-rail kit onto the back of the switch, right in the middle of the back panel.

**Step 2:** Slide the switch onto a DIN-rail from the Din-rail kit and make sure the switch clicks into the rail firmly.

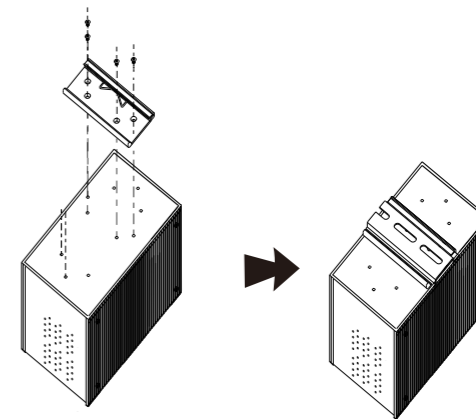

#### Wall-mounting

**Step 1:** Screw the two pieces of wall-mount kits onto both ends of the rear panel of the switch. A total of six screws are required, as shown below.

**Step 2:** Use the switch, with wall mount plates attached, as a guide to mark the correct locations of the four screws.

**Step 3:** Insert a screw head through the large parts of the keyhole-shaped apertures, and then slide the switch downwards. Tighten the screws for added stability.

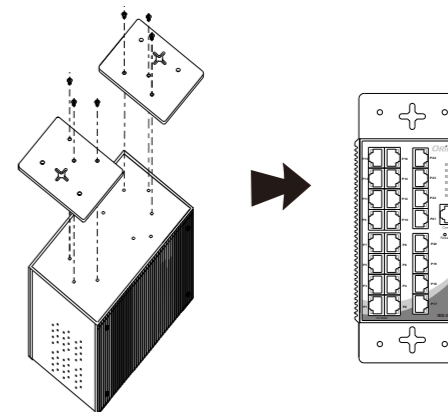

#### Network Connection

The switch provides standard Ethernet ports. According to the link type, the switch uses CAT 3,4,5,e UTP cables to connect to any other network devices (PCs, servers, switches, routers, or hubs). Please refer to the following table for cable specifications.

#### Cable Types and Specifications:

Cable	Type	Max. Length	Connector
10BASE-T	Cat. 3, 4, 5 100-ohm	UTP 100 m (328 ft)	RJ-45
100BASE-TX	Cat. 5 100-ohm UTP	UTP 100 m (328 ft)	RJ-45

### Configurations

For pin assignments for different types of cables, please refer to the following tables.

10/100 Base-T(X) RJ-45 Port		10/100 Base-T(X) MDI/MDI-X		
Pin Number	Assignments	Pin Number	MDI port	MDI-X port
1	TD+	1	TD+(transmit)	RD+(receive)
2	TD-	2	TD-(transmit)	RD-(receive)
3	RD+	3	RD+(receive)	TD+(transmit)
4	Not used	4	Not used	Not used
5	Not used	5	Not used	Not used
6	RD-	6	RD-(receive)	TD-(transmit)
7	Not used	7	Not used	Not used
8	Not used	8	Not used	Not used

Note: "+" and "-" signs represent the polarity of the wires that make up each wire pair.

#### Console Port Pin Definition

To connect the console port to an external management device, you need an RJ-45 to DB-9 cable, which is also supplied in the package. Below is the console port pin assignment information.

PC (male) pin assignment	RS-232 with DB9 (female) pin assignment (RJ45-DB9 cable)	RJ45 pin assignment
PIN#2 RxD	PIN#2 RxD	PIN#2 RxD
PIN#3 TxD	PIN#3 TxD	PIN#3 TxD
PIN#5 GND	PIN#5 GND	PIN#5 GND

#### Wiring

##### Power inputs

The switch supports dual redundant power supplies, Power Supply 1 (PWR1) and Power Supply 2 (PWR2). The connections for PWR1, PWR2 and the RELAY are located on the terminal block.

**STEP 1:** Insert the negative/positive wires into the V-/V+ terminals, respectively.

**STEP 2:** To keep the DC wires from pulling loose, use a small flat-blade screwdriver to tighten the wire-clamp screws on the front of the terminal block connector.

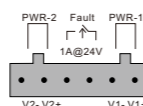

##### Relay contact

The two sets of relay contacts of the 6-pin terminal block connector are used to detect user-configured events. The two wires attached to the fault contacts form an open circuit when a user-configured when an event is triggered. If a user-configured event does not occur, the fault circuit remains closed.

##### Grounding

Grounding and wire routing help limit the effects of noise due to electromagnetic interference (EMI). Run the ground connection from the ground screws to the grounding surface prior to connecting devices.

Contact for maintenance and repair service:

## ORing

Copyright© 2010 ORing  
All rights reserved.



ORing Industrial Networking Corp.

TEL: +886-2-2218-1066 Website: www.oringnet.com  
FAX: +886-2-2218-1014 E-mail: support@oringnet.com  
Address: 3F., No.542-2, Zhongzheng Rd., Xindian Dist., New Taipei City 23148, Taiwan

After installing the switch, the green power LED should turn on. Please refer to the following table for LED indication.

LED	Color	Status	Description
PWR	Green	On	DC power on
PWR1	Green	On	DC power module 1 activated
PWR2	Green	On	DC power module 2 activated
R.M	Green	On	Ring Master
Ring	Green	On	Ring enabled
		Blinking	Ring structure is broken (i.e. part of the ring is disconnected)
Fault	Amber	On	Faulty relay (power failure or port disconnected)

10/100Base-T(X) Ethernet ports			
LNK/ACT with speed	Green	On	Port link up
		Blinking	Data transmitted
	Amber	On	Full-duplex mode
		Off	Half-duplex mode
		Blinking	Half-duplex mode and collision occurred

Follow the steps to set up the switch:

1. Launch the Internet Explorer and type in IP address of the switch. The default static IP address is **192.168.10.1**

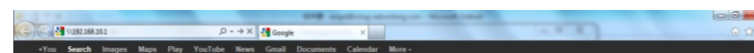

2. Log in with default user name and password (both are **admin**). After logging in, you should see the following screen. For more information on configurations, please refer to the user manual. For information on operating the switch using ORing's Open-Vision management utility, please go to ORing website.



#### Resetting

To reboot the switch, press the **Reset** button less than 5 seconds.

To restore the switch configurations back to the factory defaults, press the **Reset** button more than 5 seconds.

### Specifications

ORing Switch Model	IES-3240
<b>Physical Ports</b>	
10/100 Base-T(X) Ports in RJ45 Auto MDI/MDIX	24
<b>Technology</b>	
Ethernet Standards	IEEE 802.3 for 10Base-T IEEE 802.3u for 100Base-TX IEEE 802.3x for Flow control IEEE 802.3ad for LACP (Link Aggregation Control Protocol) IEEE 802.1D for STP (Spanning Tree Protocol) IEEE 802.1p for COS (Class of Service) IEEE 802.1Q for VLAN Tagging IEEE 802.1w for RSTP (Rapid Spanning Tree Protocol) IEEE 802.1s for MSTP (Multiple Spanning Tree Protocol) IEEE 802.1x for Authentication IEEE 802.1AB for LLDP (Link Layer Discovery Protocol)
MAC Table	8K
Packet buffer	1Mbits
Priority Queues	4
Processing	Store-and-Forward
Switch Properties	Switch latency: 2.96 us Switch bandwidth: 4.8Gbps Throughput (packet per second): 3.571Mpps@64Bytes packet Max. Number of Available VLANs: 4096 VLAN ID Range: VID 1 to 4095 IGMP multicast groups: 1024 Port rate limiting: User Define

Security Features	Enable/disable ports, MAC based port security Port based network access control (802.1x) VLAN (802.1Q) to segregate and secure network traffic Supports Q-in-Q VLAN for performance & security to expand the VLAN space Radius centralized password management SNMP V1/V2c/V3 encrypted authentication and access security
Software Features	STP/RSTP/MSTP (IEEE 802.1D/w/s) Redundant Ring (O-Ring) with recovery time less than 10ms over 250 units TOS/Diffserv supported Quality of Service (802.1p) for real-time traffic VLAN (802.1Q) with VLAN tagging and GVRP supported IGMP Snooping for multicast filtering Port configuration, status, statistics, monitoring, security SNTP for synchronizing of clocks over network Support PTP Client (Precision Time Protocol) clock synchronization DHCP Server / Client support Port Trunk support MVR (Multicast VLAN Registration) support Modbus TCP
Network Redundancy	O-Ring, O-Chain, MRP**NOTE, MSTP/RSTP/STP
RS-232 Serial Console Port	RS-232 in RJ45 connector with console cable. 9600bps, 8, N, 1
<b>Fault contact</b>	
Relay	Relay output to carry capacity of 1A at 24 VDC
<b>Reset Function</b>	
Reset Button	< 5 sec: System reboot, > 5 sec: Factory default
<b>Power</b>	
Redundant Input power	Dual DC inputs 12-48VDC on 6-pin terminal block * Supplied by SELV source evaluated by UL 61010-1 or 61010-2-201 power supply only. * Fourni par la source SELV évaluée uniquement par l'alimentation UL 61010-1 or 61010-2-201.
Power consumption(Typ.)	15Watts, 12-48VDC/1.2A-0.3A
Overload current protection	Present
Reverse polarity protection	Present on terminal block
<b>Physical Characteristic</b>	
Enclosure	IP-30 Aluminum (non UL certified)
Dimension (W x D x H)	96.4(W)x108.5(D)x154(H) mm (3.8x4.27x6.06 inch.)
Weight (g)	1052 g
<b>Environmental</b>	
Storage Temperature	-40 to 85°C (-40 to 185°F)
Operating Temperature	-40 to 75°C (-40 to 167°F)
Operating Humidity	5% to 95% Non-condensing
Operating Altitude	Up to 2000m
<b>Regulatory approvals</b>	
EMC	CE EMC (EN 55024, EN 55032), FCC Part 15 B
EMI	EN 55032, CISPR32, EN 61000-3-2, EN 61000-3-3, FCC Part 15 B class A
EMS	EN 55024 (IEC/EN 61000-4-2 (ESD: Contact 4KV, Air 8KV), IEC/EN 61000-4-3 (RS: 3V), IEC/EN 61000-4-4 (EFT Power 0.5KV, Signal 0.5KV), IEC/EN 61000-4-5 (Surge: Power 0.5KV, RJ45 1KV), IEC/EN 61000-4-6 (CS: 3V), IEC/EN 61000-4-8(PFME), IEC/EN 61000-4-11 (DIP)) EN 61000-6-2 (IEC/EN 61000-4-2 (ESD: Contact 4KV), IEC/EN 61000-4-3 (RS: 10V), IEC/EN 61000-4-4 (EFT Power 2KV, Signal 1KV), IEC/EN 61000-4-5 (Surge: Power 1KV, RJ45 1KV), IEC/EN 61000-4-6 (CS: 10V), IEC/EN 61000-4-8(PFME), IEC/EN 61000-4-11 (DIP))
Shock	IEC60068-2-27
Free Fall	IEC60068-2-31
Vibration	IEC60068-2-6
Safety	EN60950-1, UL61010-1, UL61010-2-201
MTBF	731,289, 4169 hrs
Warranty	5 years

\*NOTE : This function is available by request only



#### Warning [AVERTISSEMENT]

Take into consideration the following guidelines before wiring the device

[Tenez compte des directives suivantes avant de câbler l'appareil.]

1. Terminal block is mating with Plug and suitable for 12-24AWG. Torque value 4.5 lb-in.

[Le bornier est compatible avec les connecteurs et convient pour 12-24AWG.

Valeur de couple 4,5 lb-in.]

2. The temperature rating of the input connection cable should higher than 105°C

[La température de service nominale du câble d'entrée doit être supérieure à 105 °C]

- \* Indoor use and pollution degree II, it must be wiped with a dry cloth for clean up the device and label.
- \* Utilisation en intérieur et degré de pollution II, il faut l'essuyer avec un chiffon sec pour nettoyer l'appareil et son étiquette.
- \* Do not block air ventilation holes.
- \* Ne bloquez pas les orifices de ventilation.
- \* If the equipment is used in a manner not specified by the manufacturer, the protection provided by the equipment may be impaired.
- \* Si l'appareil est utilisé d'une manière non spécifiée par le fabricant, la protection qu'il apporte peut se voir diminuée.
- \* Shall be mounted in the Industrial Control Panel and ambient temperature is not exceed 75 degree C
- \* doit être monté dans le panneau de commande industriel et la température ambiante ne doit pas dépasser 75 degrés C