

Quick Installation Guide

IES-2050A

Industrial Lite-Managed Switch

Introduction

IES-2050A is a lite-managed Ethernet switch. With very compact size of housing, you can install **IES-2050A** easily. In addition, it also supports of Ethernet Redundancy protocol, O-Ring (recovery time < 10ms over 250 units of connection), O-Chain and STP/RSTP (IEEE802.1w/D) can protect your mission-critical applications from network interruptions or temporary malfunctions with its fast recovery technology. **IES-2050A** provides the setting ability of Web-GUI and Windows Utility, also support the simple DIP-Switch setting function which offer great flexibility to set up the Ring. **IES-2050A** is with rigid IP-30 housing design and can operate under harsh environment. The feature of wide operating temperature ranges from -40°C to 75°C can satisfy most requirement of operation.





• **O-Ring:** O-Ring is ORing's proprietary redundant ring technology, with recovery time of less 10 milliseconds and up to 250 nodes. The O-Ring redundant ring technology can protect mission-critical application from network interruptions or temporary malfunction with its fast recover technology.

• **O-Chain:** O-Chain is the revolutionary network redundancy technology that provides the add-on network redundancy topology for any backbone network, O-Chain allows multiple redundant network rings of different redundancy protocols to join and function together as a larger and more robust compound network topology. O-Chain providing ease-of-use while maximizing fault-recovery swiftness, flexibility, compatibility, and cost-effectiveness in one set of network redundancy topology.

The product is open type, intended to be installed in and industrial control panel or an enclosure.

Package Contents



The device is shipped with the following items. If any of these items is missing or damaged, please contact your customer service representative for assistance.

Contents	Pictures	Number
IES-2050A		X 1
CD		X 1
DIN-rail Kit		X 1
Wall-mount Kit		X 2
QIG		X 1

Preparation

Before you begin installing the device, make sure you have all of the package contents available and a PC with Microsoft Internet Explorer 6.0 or later, for using web-based system management tools.

Safety & Warnings

-  **Elevated Operating Ambient:** If installed in a closed environment, make sure the operating ambient temperature is compatible with the maximum ambient temperature (T_{ma}) specified by the manufacturer.
-  **Reduced Air Flow:** Make sure the amount of air flow required for safe operation of the equipment is not compromised during installation.

 **Mechanical Loading:** Make sure the mounting of the equipment is not in a hazardous condition due to uneven mechanical loading.

 **Circuit Overloading:** Consideration should be given to the connection of the equipment to the supply circuit and the effect that overloading of the circuits might have on overcurrent protection and supply wiring. Appropriate consideration of equipment nameplate ratings should be used when addressing this concern.

Dimension Unit =mm (Tolerance ±0.5mm)

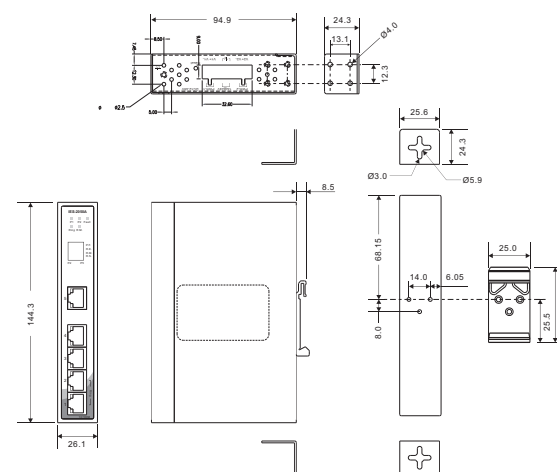

Panel Layouts

Front View

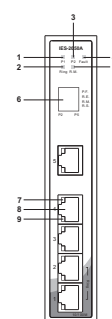

1. Power 1 LED
2. R.M status LED
3. Power 2 LED
4. Fault indicator
5. Ring status LED
6. DIP switch
7. LNK/ACT LED for LAN ports
8. LAN port
9. Duplex/Collision LED for LAN ports

Top View

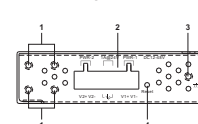

1. Wall-mount screw holes
2. Terminal block
3. Reset button
4. Ground wire

Rear View

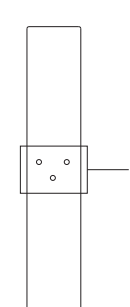

1. Din-rail screw holes

Installation

Use the mounting kits attached with the package and follow the steps below to install the switch to a rail or to the wall.

DIN-rail Installation

- Step 1:** Slant the switch and screw the Din-rail kit onto the back of the switch, right in the middle of the back panel.
- Step 2:** Slide the switch onto a DIN-rail from the Din-rail kit and make sure the switch clicks into the rail firmly.

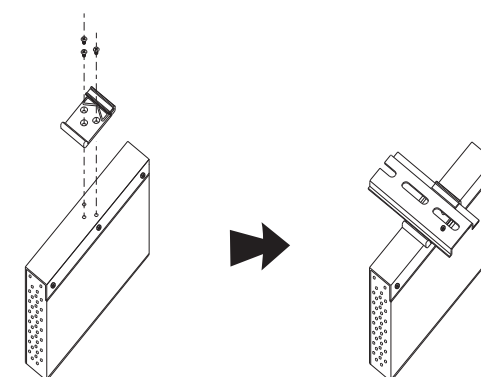



Wall-mounting

- Step 1:** Screw the wall-mount kit (in the package) onto the back of the switch. A total of eight screws are required, as shown below.

- Step 2:** Use the switch, with wall mount plates attached, as a guide to mark the correct locations of the wall-mounting screws.

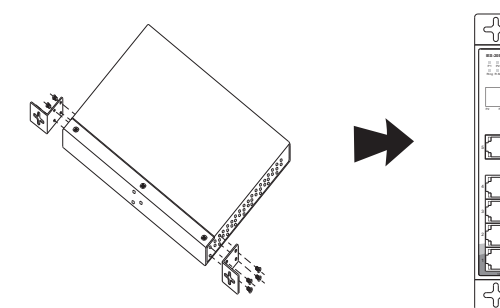
- Step 3:** Insert a screw head through the large part of the keyhole-shaped aperture on the plate, and then slide the switch downwards. Tighten the screw for added stability.



-  Instead of screwing the screws in all the way, it is advised to leave a space of about 2mm to allow room for sliding the switch between the wall and the screws.

Network Connection

The series have standard Ethernet ports. Depending on the link type, the switch uses CAT 3, 4, 5, 5e UTP cables to connect to network devices (PCs, servers, switches, routers, or hubs). Please refer to the following table for cable specifications.

Cable Types and Specifications:

Cable	Type	Max. Length	Connector
10BASE-T	Cat. 3, 4, 5 100-ohm	UTP 100 m (328 ft)	RJ-45
100BASE-TX	Cat. 5 100-ohm UTP	UTP 100 m (328 ft)	RJ-45

For pin assignments for different types of cables, please refer to the following tables.

10/100 Base-T(X) RJ-45		10/100 Base-T(X) MDI/MDI-X		
Pin Number	Assignment	Pin Number	MDI port	MDI-X port
1	TD+	1	TD+(transmit)	RD+(receive)
2	TD-	2	TD-(transmit)	RD-(receive)
3	RD+	3	RD+(receive)	TD+(transmit)
4	Not used	4	Not used	Not used
5	Not used	5	Not used	Not used
6	RD-	6	RD-(receive)	TD-(transmit)
7	Not used	7	Not used	Not used
8	Not used	8	Not used	Not used

Note: "+" and "-" signs represent the polarity of the wires that make up each wire pair.

DIP-Switch setting

P.F.	Trigger alert when power fails (On: Enable, Off: Disable function)
R.E.	Enable/Disable O-Ring function (On: Enable, Off: Disable)
R.M.	Enable/Disable Ring Master Mode (On: Enable, Off: Disable)
R.S.	Select O-Ring redundant port (On: ring port set to port-5 and port-6, Off: ring port set to port-1 and port-2)

Wiring

Power inputs

The device has two sets of power inputs, power input 1 and power input 2. Follow the steps below to wire redundant power

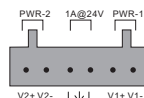

STEP 1: Insert the negative/positive wires into the V-/V+ terminals, respectively.
STEP 2: To keep the wires from pulling loose, use a small flat-blade screwdriver to tighten the wire-clamp screws on the front of the connector.

Relay contact

The two relay contacts on the terminal block allow you to form fail close circuits. The relay contacts will respond to user-configured events according to the wiring.

Grounding

Grounding and wire routing help limit the effects of noise due to electromagnetic interference (EMI). Run the ground connection from the ground screws to the grounding surface prior to connecting devices.

Contact for maintenance and repair service:

Copyright© 2015 ORing
All rights reserved.



ORing Industrial Networking Corp.

TEL: +886-2-2218-1066 Website: www.oringnet.com
 FAX: +886-2-2218-1014 E-mail: support@oringnet.com
 Address: 3F., No.542-2, Zhongzheng Rd., Xindian Dist., New Taipei City 23148, Taiwan

Configurations

After installing the switch, the green power LED should turn on. Please refer to the following tablet for LED indication.

LED	Color	Status	Description
P1	Green	On	Power module 1 is activated
P2	Green	On	Power module 2 is activated
R.M	Green	On	System running in Ring Master mode
Ring	Green	On	System running in Ring mode
		Blinking	Ring structure is broken (i.e. part of the ring is disconnected)
Fault	Amber	On	Faulty relay (power failure or port malfunctioning)
10/100Base-T(X) Fast Ethernet ports			
LNK /ACT	Green	On	Links are connected
		Blinking	Transmitting data
Duplex/ Collision	Amber	On	Full-duplex mode
		Off	Half-duplex mode
		Blinking	Half-duplex and collision occurred

Follow the steps to set up the card:

1. Launch the Internet Explorer and type in IP address of the switch. The default static IP address is 192.168.10.1

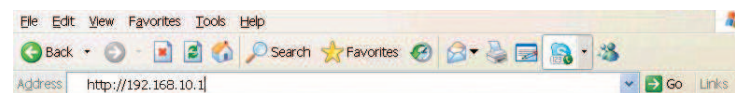

2. Log in with default user name and password (both are admin). After logging in, you should see the following screen. For more information on configurations, please refer to the user manual. For information on operating the switch using ORing's Open-Vision management utility, please go to ORing website.



Resetting

To reboot the switch, press the **Reset** button for 2-3 seconds.

To restore the switch configurations back to the factory defaults, press the **Reset** button for 5 seconds.

Specifications

ORing Switch Model	IES-2050A
Physical Ports	
10/100 Base-T(X) Ports in RJ45 Auto MDI/MDIX	5
Technology	
Ethernet Standards	IEEE 802.3 for 10Base-TX IEEE 802.3u for 100Base-TX IEEE 802.3x for Flow control IEEE 802.1D for STP (Spanning Tree Protocol) IEEE 802.1w for RSTP (Rapid Spanning Tree Protocol) IEEE 802.1AB for LLDP (Link Layer Discovery Protocol)
MAC Table	1K
Packet buffer	1Mbits
Priority Queues	4
Processing	Store-and-Forward
Switch Properties	Switching latency: 8.94 μ s Switching bandwidth: 1Gbps Throughput (packet per second): 76.19Mpps@64Bytes packet VLAN: Port based

Security Features	Enable/disable ports, VLAN to segregate and secure network traffic
Software Features	STP/RSTP (IEEE 802.1D/w) Redundant Ring (O-Ring) with recovery time less than 10ms over 250units DHCP Client Port base VLAN LLDP (Link Layer Discovery Protocol) Port configuration, status, statistics, monitoring, security SNMP v1/v2c/v3 and private MIB support
Network Redundancy	O-Ring O-Chain Fast recovery RSTP/STP
Fault Contact	
Relay	Relay output to carry capacity of 1A at 24 VDC
Power	
Redundant Input power	Dual DC inputs, 12~48VDC on 6-pin terminal block
Power consumption(Typ.)	\leq 4Watts, 12VDC/0.29A (3W), 24VDC/0.14A (3W), 48VDC/0.08A (4W) * Supplied by SELV source evaluated by UL 61010-1 or 61010-2-201 power supply only. * Fourni par la source SELV évaluée uniquement par l'alimentation UL 61010-1 or 61010-2-201.
Overload current protection	Present
Reverse polarity protection	Present on terminal block
Physical Characteristic	
Enclosure	IP-30 Metal (non UL certified)
Dimension (W x D x H)	26.1 mm (W) x 95 mm (D) x 144.3(H) mm (1.03 x 3.74 x 5.68 inch.)
Weight (g)	395 g
Environmental	
Storage Temperature	-40 to 85°C (-40 to 185°F)
Operating Temperature	-40 to 75°C (-40 to 167°F)
Operating Humidity	5% to 95% Non-condensing
Operating Altitude	Up to 2000m
Regulatory Approvals	
EMC	CE EMC (EN 55024, EN 55032, EN 61000-6-2, EN 61000-6-4), FCC Part 15 B
EMI	EN 55032, EN 61000-6-4, CISPR32, EN 61000-3-2, EN 61000-3-3, VCCI class A, FCC Part 15 B class A
EMS	EN 55024 (IEC/EN 61000-4-2 (ESD: Contact 4KV, Air 8KV), IEC/EN 61000-4-3 (RS: 3V), IEC/EN 61000-4-4 (EFT Power 0.5KV, Signal 0.5KV), IEC/EN 61000-4-5 (Surge: Power 0.5KV), IEC/EN 61000-4-6 (CS: 3V), IEC/EN 61000-4-8(PFME), IEC/EN 61000-4-11 (DIP)) EN 61000-6-2 (IEC/EN 61000-4-2 (ESD: Contact 4KV, Air 8KV), IEC/EN 61000-4-3 (RS: 10V), IEC/EN 61000-4-4 (EFT Power 2KV, Signal 1KV), IEC/EN 61000-4-5 (Surge: Power 0.5KV), IEC/EN 61000-4-6 (CS: 10V), IEC/EN 61000-4-8(PFME), IEC/EN 61000-4-11 (DIP))
Shock	IEC60068-2-27
Free Fall	IEC60068-2-31
Vibration	IEC60068-2-6
Safety	EN 60950-1 (LVD)
MTBF	1796601.9604 hrs
Warranty	5 years



Warning [AVERTISSEMENT]

Take into consideration the following guidelines before wiring the device [Tenez compte des directrices suivantes avant de câbler l'appareil.]

- Terminal block is mating with Plug and suitable for 12-24AWG. Torque value 4.5 lb-in.
[Le bornier est compatible avec les connecteurs et convient pour 12-24AWG. Valeur de couple 4,5 lb-in.]
- The temperature rating of the input connection cable should higher than 105°C [La température de service nominale du câble d'entrée doit être supérieure à 105 °C]

- * Indoor use and pollution degree II, it must be wiped with a dry cloth for clean up the device and label.
- * Utilisation en intérieur et degré de pollution II, il faut l'essuyer avec un chiffon sec pour nettoyer l'appareil et son étiquette.
- * Do not block air ventilation holes.
- * Ne bloquez pas les orifices de ventilation.
- * If the equipment is used in a manner not specified by the manufacturer, the protection provided by the equipment may be impaired.
- * Si l'appareil est utilisé d'une manière non spécifiée par le fabricant, la protection qu'il apporte peut se voir diminuée.
- * Shall be mounted in the Industrial Control Panel and ambient temperature is not exceed 75 degree C
- * doit être monté dans le panneau de commande industriel et la température ambiante ne doit pas dépasser 75 degrés C