

Introduction

IES-2042PA is a lite-managed industrial Ethernet switch with a compact size for the ease of installation. The device supports several Ethernet redundancy protocols including O-Ring (recovery time < 10ms over 250 units of connection), Open-Ring, O-Chain, and STP/RSTP (IEEE802.1w/D) to protect your mission-critical applications from network interruptions or temporary malfunctions. **IES-2042PA** can be configured via Web-GUI and Windows Utility and supports simple DIP-Switch setting functions for higher flexibility. With rigid IP-30 housing design and a wide operating temperature range from -40°C to 70°C, the device can operate in harsh environments.

Package Contents

The device is shipped with the following items. If any of these items is missing or damaged, please contact your customer service representative for assistance.

Contents	Pictures	Number
IES-2042PA		X 1
CD		X 1
DIN-rail Kit		X 1
Wall-mount Kit		X 2
QIG		X 1

Preparation

Before you begin installing the device, make sure you have all of the package contents available and a PC with Microsoft Internet Explorer 6.0 or later, for using web-based system management tools.

Safety & Warnings

- Elevated Operating Ambient:** If installed in a closed environment, make sure the operating ambient temperature is compatible with the maximum ambient temperature (T_{ma}) specified by the manufacturer.
- Reduced Air Flow:** Make sure the amount of air flow required for safe operation of the equipment is not compromised during installation.
- Mechanical Loading:** Make sure the mounting of the equipment is not in a hazardous condition due to uneven mechanical loading.
- Circuit Overloading:** Consideration should be given to the connection of the equipment to the supply circuit and the effect that overloading of the circuits might have on overcurrent protection and supply wiring. Appropriate consideration of equipment nameplate ratings should be used when addressing this concern.

Dimension

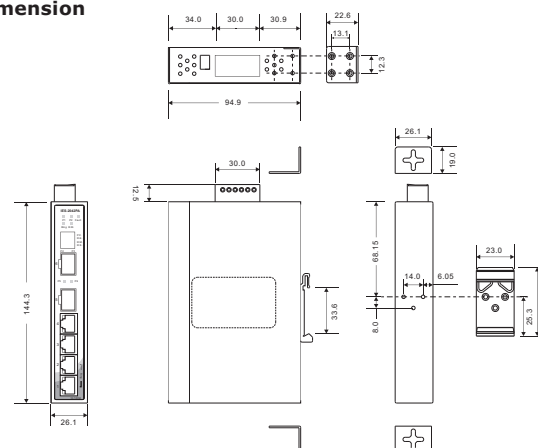

Panel Layouts

Front View

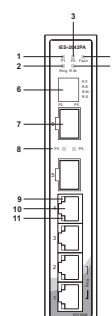

1. PWR1 LED
2. R.M status LED
3. PWR2 LED
4. Fault indicator
5. Ring status LED
6. DIP switch
7. SFP port
8. LNK/ACT LED for SFP ports
9. LNK/ACT LED for LAN ports
10. LAN port
11. LNK LED for LAN ports

Top View

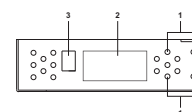

1. Wall-mount screw holes
2. Terminal block
3. DIP switch for relay output

Rear View

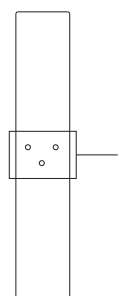

1. Din-rail screw holes

Installation

Use the mounting kits attached with the package and follow the steps below to install the switch to a rail or to the wall.

DIN-rail Installation

Step 1: Slant the switch and screw the Din-rail kit onto the back of the switch, right in the middle of the back panel.
Step 2: Slide the switch onto a DIN-rail from the Din-rail kit and make sure the switch clicks into the rail firmly.

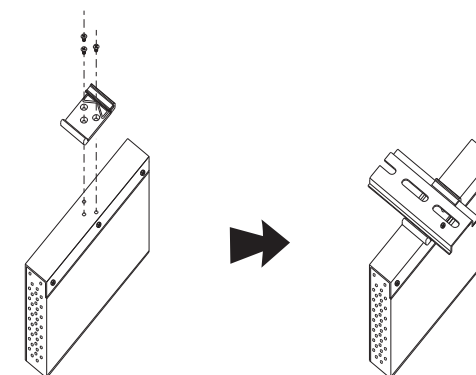

Wall-mounting

Step 1: Screw the wall-mount kit (in the package) onto the back of the switch. A total of eight screws are required, as shown below.

Step 2: Use the switch, with wall mount plates attached, as a guide to mark the correct locations of the wall-mounting screws.

Step 3: Insert a screw head through the large part of the keyhole-shaped aperture on the plate, and then slide the switch downwards. Tighten the screw for added stability.

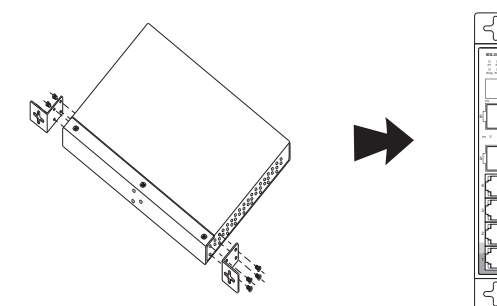

Instead of screwing the screws in all the way, it is advised to leave a space of about 2mm to allow room for sliding the switch between the wall and the screws.

Network Connection

The series have standard Ethernet ports. Depending on the link type, the switch uses CAT 3, 4, 5, 5e UTP cables to connect to network devices (PCs, servers, switches, routers, or hubs). Please refer to the following table for cable specifications.

Cable Types and Specifications:

Cable	Type	Max. Length	Connector
10BASE-T	Cat. 3, 4, 5 100-ohm	UTP 100 m (328 ft)	RJ-45
100BASE-TX	Cat. 5 100-ohm UTP	UTP 100 m (328 ft)	RJ-45

For pin assignments for different types of cables, please refer to the following tables.

10/100 Base-T(X) RJ-45		10/100 Base-T(X) MDI/MDI-X		
Pin Number	Assignment	Pin Number	MDI port	MDI-X port
1	TD+	1	TD+(transmit)	RD+(receive)
2	TD-	2	TD-(transmit)	RD-(receive)
3	RD+	3	RD+(receive)	TD+(transmit)
4	Not used	4	Not used	Not used
5	Not used	5	Not used	Not used
6	RD-	6	RD-(receive)	TD-(transmit)
7	Not used	7	Not used	Not used
8	Not used	8	Not used	Not used

Note: "+" and "-" signs represent the polarity of the wires that make up each wire pair.

DIP setting

P.F.	Trigger alert when power fails (On: Enable, Off: Disable function)
R.E.	Enable/Disable O-Ring function (On: Enable, Off: Disable)
R.M.	Enable/Disable Ring Master Mode (On: Enable, Off: Disable)
R.S.	Select O-Ring redundant port (On: ring port set to port-5 and port-6, Off: ring port set to port-1 and port-2)

Wiring

Power inputs

The device has two sets of power inputs, power input 1 and power input 2. Follow the steps below to wire redundant power

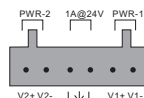

STEP 1: Insert the negative/positive wires into the V-/V+ terminals, respectively.
STEP 2: To keep the wires from pulling loose, use a small flat-blade screwdriver to tighten the wire-clamp screws on the front of the connector.

Relay contact

The two relay contacts on the terminal block allow you to form fail close circuits. The relay contacts will respond to user-configured events according to the wiring.

Grounding

Grounding and wire routing help limit the effects of noise due to electromagnetic interference (EMI). Run the ground connection from the ground screws to the grounding surface prior to connecting devices.

Copyright© 2014 ORing
All rights reserved.

ORing Industrial Networking Corp.
 TEL: +886-2-2218-1066 Website: www.oring-networking.com
 FAX: +886-2-2218-1014 E-mail: support@oring-networking.com

Configurations

After installing the switch, the green power LED should turn on. Please refer to the following table for LED indication.

LED	Color	Status	Description
PWR	Green	On	Power is on
PW1	Green	On	Power module 1 is activated
PW2	Green	On	Power module 2 is activated
R.M	Green	On	System running in Ring Master mode
Ring	Green	On	System running in Ring mode
		Blinking	Ring structure is broken (i.e. part of the ring is disconnected)
Fault	Amber	On	Faulty relay (power failure or port malfunctioning)
10/100Base-T(X) Fast Ethernet ports			
LNK	Green	On	Links are connected
/ACT		Blinking	Transmitting data
LNK	Amber	On	Links are connected
/ACT		Blinking	Transmitting data
SFP			
LNK	Green	On	Links are connected
/ACT		Blinking	Transmitting data

Follow the steps to set up the card:

1. Launch the Internet Explorer and type in IP address of the switch. The default static IP address is **192.168.10.1**

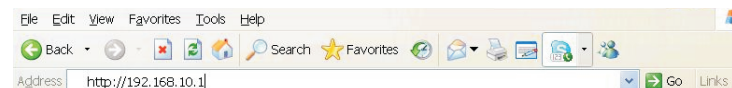

2. Log in with default user name and password (both are **admin**). After logging in, you should see the following screen. For more information on configurations, please refer to the user manual. For information on operating the switch using ORing's Open-Vision management utility, please go to ORing website.



Resetting

To restore the switch configurations back to the factory defaults and reboot the device, press the **Reset** button for 5 seconds.

Specifications

ORing Switch Model	IES-2042PA		
Physical Ports			
10/100 Base-T(X) Ports in RJ45 Auto MDI/MDIX			4
100Base-FX SFP Ports			2
Technology			
Ethernet Standards	IEEE 802.3 for 10Base-T, IEEE 802.3u for 100Base-TX and 100Base-FX, IEEE 802.3x for Flow control, IEEE 802.1D for STP (Spanning Tree Protocol), IEEE 802.1w for RSTP (Rapid Spanning Tree Protocol), IEEE 802.1AB for LLDP (Link Layer Discovery Protocol),		

MAC Table	1024 MAC addresses
Priority Queues	4
Processing	Store-and-Forward
Switch Properties	Switch bandwidth: 1.2Gbps VLANs: Port Based
Security Features	Enable/disable ports, VLAN to segregate and secure network traffic
Software Features	STP/RSTP (IEEE 802.1D/w) Redundant Ring (O-Ring) with recovery time less than 10ms over 250units DHCP Client Port base VLAN LLDP (Link Layer Discovery Protocol) Port configuration, status, statistics, monitoring, security SNMP v1/v2c/v3 and private MIB support
Network Redundancy	O-Ring, Open-Ring, STP, RSTP, Fast recovery, O-Chain
Fault Contact	
Relay	Relay output to carry capacity of 1A at 24 VDC
Power	
Input power	12~48 VDC power inputs on 6pin terminal block
Power consumption(Typ.)	7 Watts max
Overload current protection	Present
Reverse polarity protection	Present
Physical Characteristic	
Enclosure	IP-30
Dimension (W x D x H)	26.1 mm (W) x 95 mm (D) x 144.3(H) mm (1.03 x 3.74 x 5.68 inch.)
Weight (g)	395 g
Environmental	
Storage Temperature	-40 to 85°C (-40 to 185°F)
Operating Temperature	-40 to 70°C (-40 to 158°F)
Operating Humidity	5% to 95% Non-condensing
Regulatory Approvals	
EMI	FCC Part 15, CISPR (EN55022) class A
EMS	EN61000-4-2 (ESD), EN61000-4-3 (RS), EN61000-4-4 (EFT), EN61000-4-5 (Surge), EN61000-4-6 (CS), EN61000-4-8, EN61000-4-11
Shock	IEC60068-2-27
Free Fall	IEC60068-2-32
Vibration	IEC60068-2-6
Safety	EN60950-1
Warranty	5 years